



OFFICE OF TASMANIAN
ASSESSMENT, STANDARDS
& CERTIFICATION

Tasmanian Certificate of Education
External Assessment 2017

PLACE YOUR CANDIDATE
LABEL HERE

TECHNICAL GRAPHICS

(TEG315115)

Time allowed for this paper

- Working time: 2 hours
- Plus 15 minutes recommended reading time

Pages:	12
Questions:	10

Candidate Instructions

1. You **MUST** make sure that your responses to the questions in this examination paper will show your achievement in the criteria being assessed.
2. There are **THREE** sections to this paper.
3. You must answer **SIX** questions.
 - **ALL FOUR** questions from Section A
 - **ONE** question from Section B
 - **ONE** question from Section C
4. Answer each question on the drawing paper provided.

You are required to use correct linework and presentation, and are encouraged to include freehand sketches, where necessary, to show the development of ideas in the solution of problems. Construction must be shown.
5. All dimensions are in millimetres unless otherwise stated.
6. All written responses must be in English.

On the basis of your performance in this examination, the examiners will provide results on each of the following criteria taken from the course statement:

Criterion 2 Apply geometric knowledge and skills in interpreting and transferring drawings.

Criterion 3 Solve geometric problems.

BLANK PAGE

SECTION A

Answer **ALL** questions in this section on the drawing paper provided.

Question 1 – This question assesses **Criterion 2**.

A light is shone through a hole cut in a screen onto the surface of a prism as shown in Figure 1. The light rays are parallel.

The true shape of the image thrown onto the prism is a 50 mm diameter circle.

The prism has a base length of 75 mm and height of 45 mm.

Construct the shape of the hole cut in the screen.

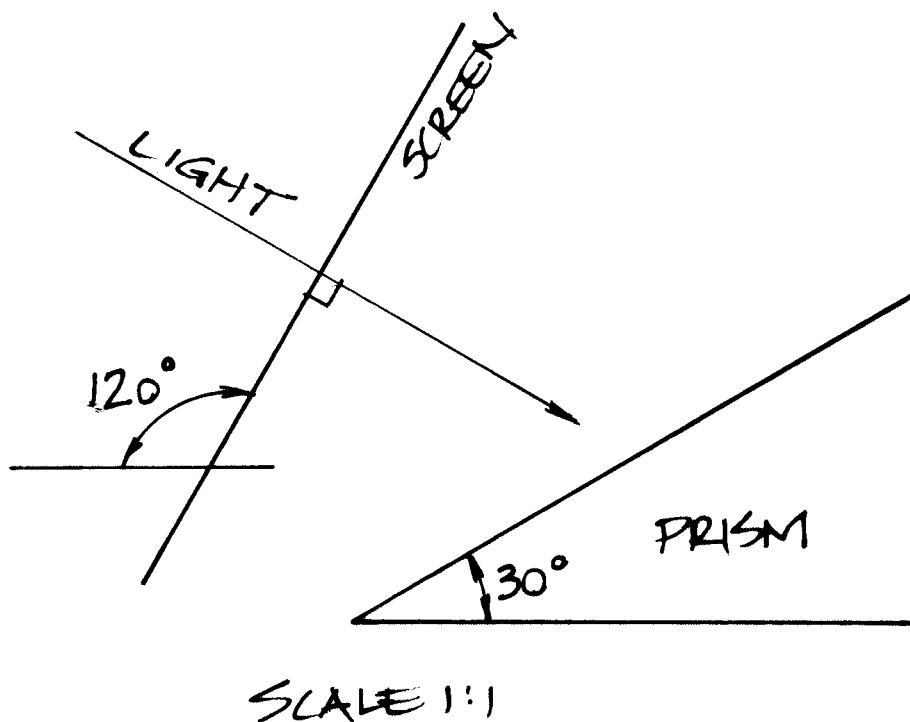

Figure 1

Section A continues.

Section A (continued)

Question 2 – This question assesses **Criterion 3**.

A and B in Figure 2 are lighthouses on a coastline.

The bearing to a ship at sea is 330° from A and 285° from B (position 1). Later it is again sighted at a bearing of 030° from A and 330° from B (position 2).

- (a) Plot position 1.
- (b) Plot position 2.
- (c) State how far the ship has travelled in kilometres.
- (d) Show by construction and state the shortest distance in kilometres between the ship and the coastline at position 2.

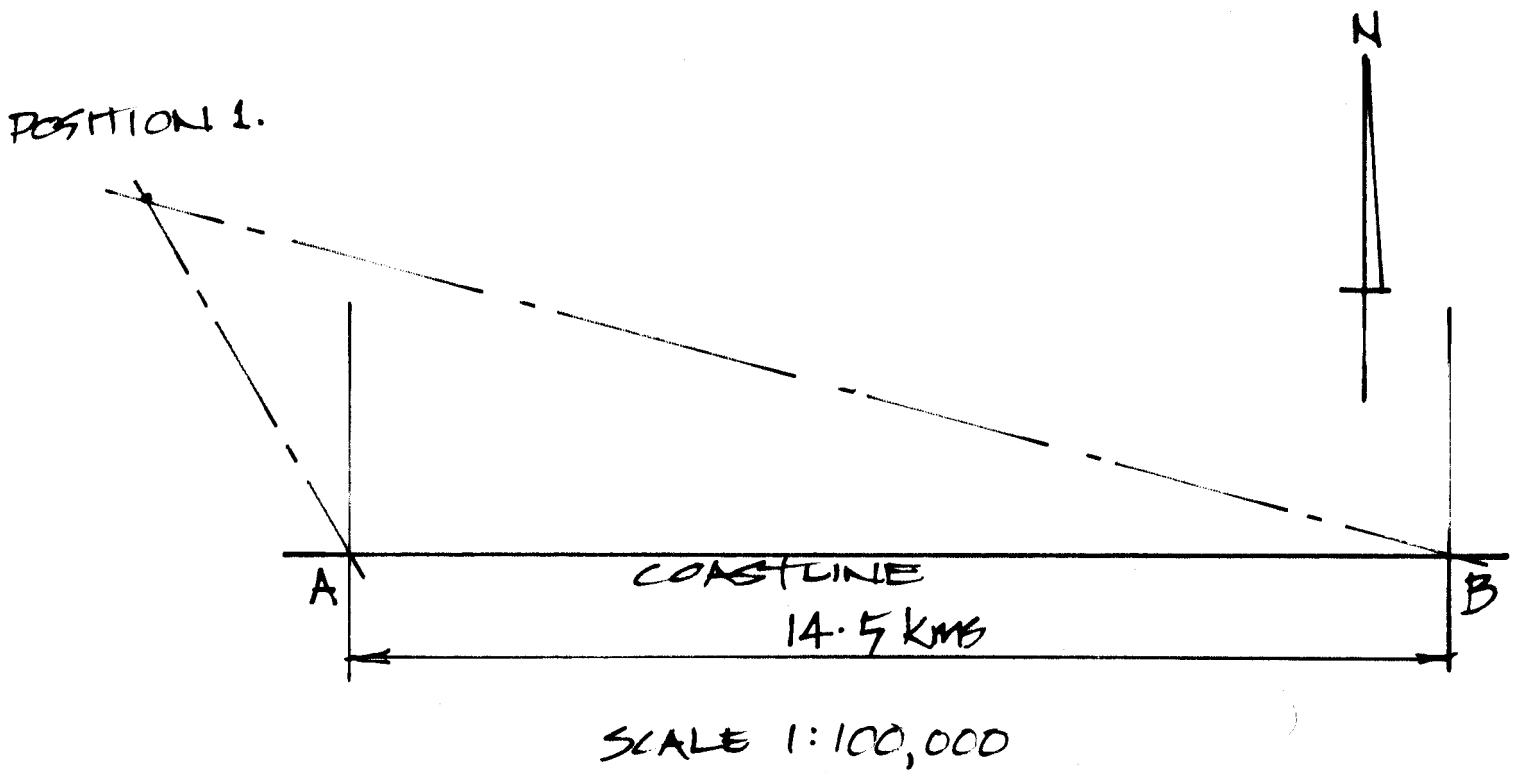

Figure 2

Section A continues.

Section A (continued)

Question 3 – This question assesses **Criteria 2 and 3** equally.

Holes have to be drilled in a metal plate as shown by crosses in Figure 3.

Draw the plate full size and find by construction the position of the holes. Fully dimension the position of the holes on the diagram (do not show any other dimensions).

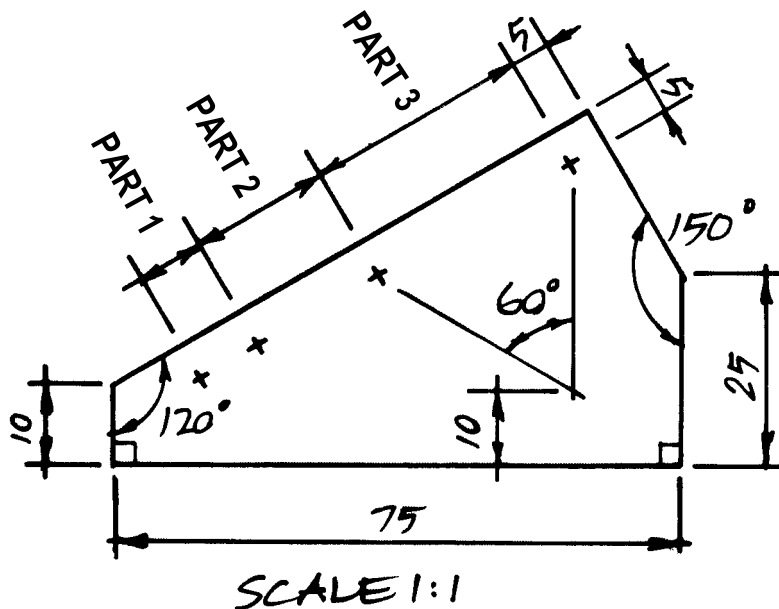

Figure 3

Question 4 – This question assesses **Criteria 2 and 3** equally.

- (a) Using a scale of 1:2 construct a pentagon on a given base of 40 mm.
- (b) Draw an involute of the pentagon.

SECTION B

Answer **ONE** question from this section on the drawing paper provided.

This section assesses **Criteria 2 and 3** weighted 1 : 4 respectively.

Question 5

- (a) In Figure 4 the circle A rolls along the arc OB until point P reaches point B. Plot the locus of P for this movement.
- (b) Once P is plotted, the arc OB rolls along the arc OC until point B reaches point C. Plot the locus of B for this movement.

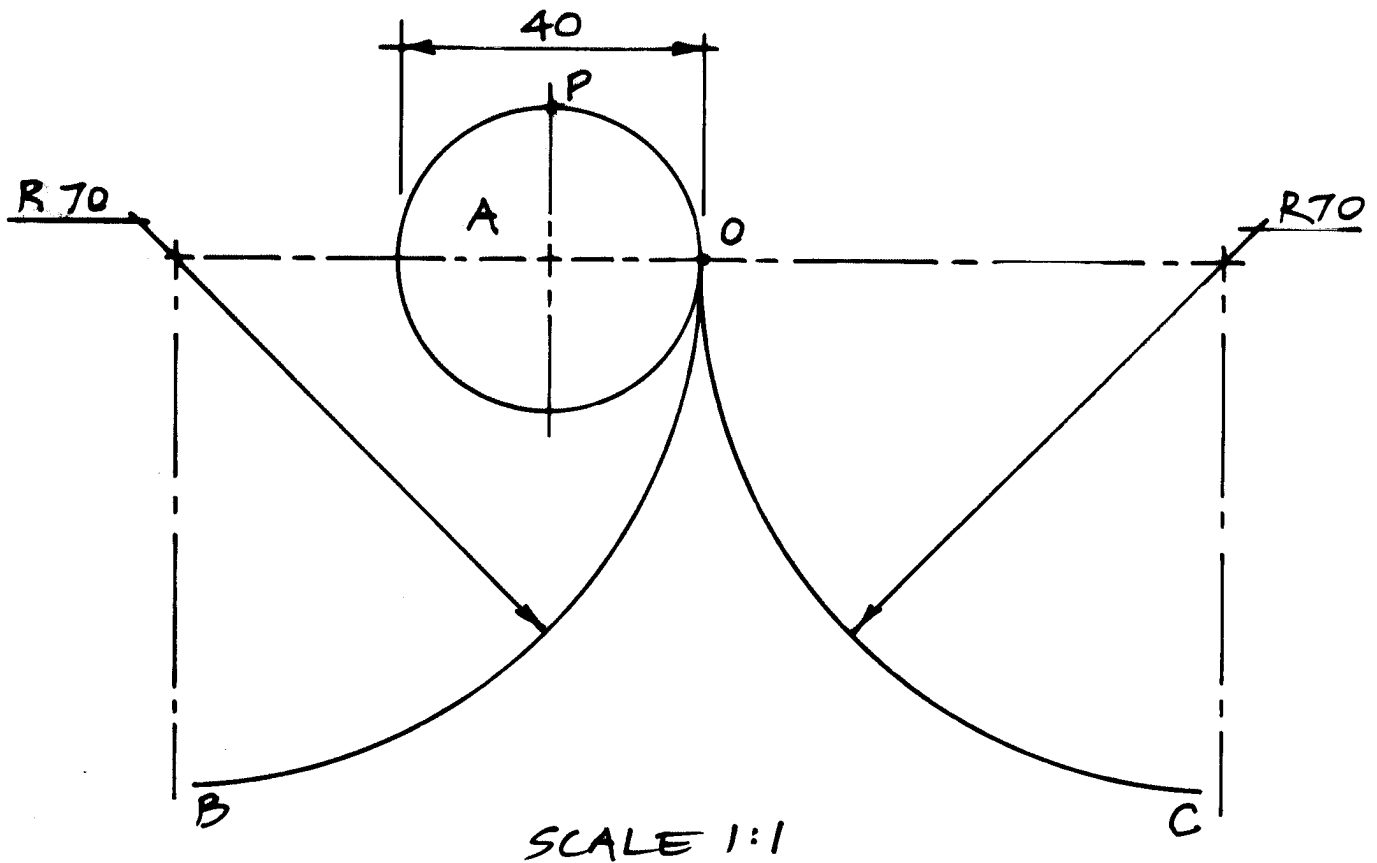

Figure 4

Section B continues.

Section B (continued)

Question 6

The plan and elevation of a cylinder with three points, A, B and P on its surface are shown in Figure 5.

- (a) Show on the elevation of the cylinder, the path of the helix which starts at point P and moves to the top of the cylinder with one revolution.
- (b) Draw the elevation of another helix that starts at point A and passes through point B.

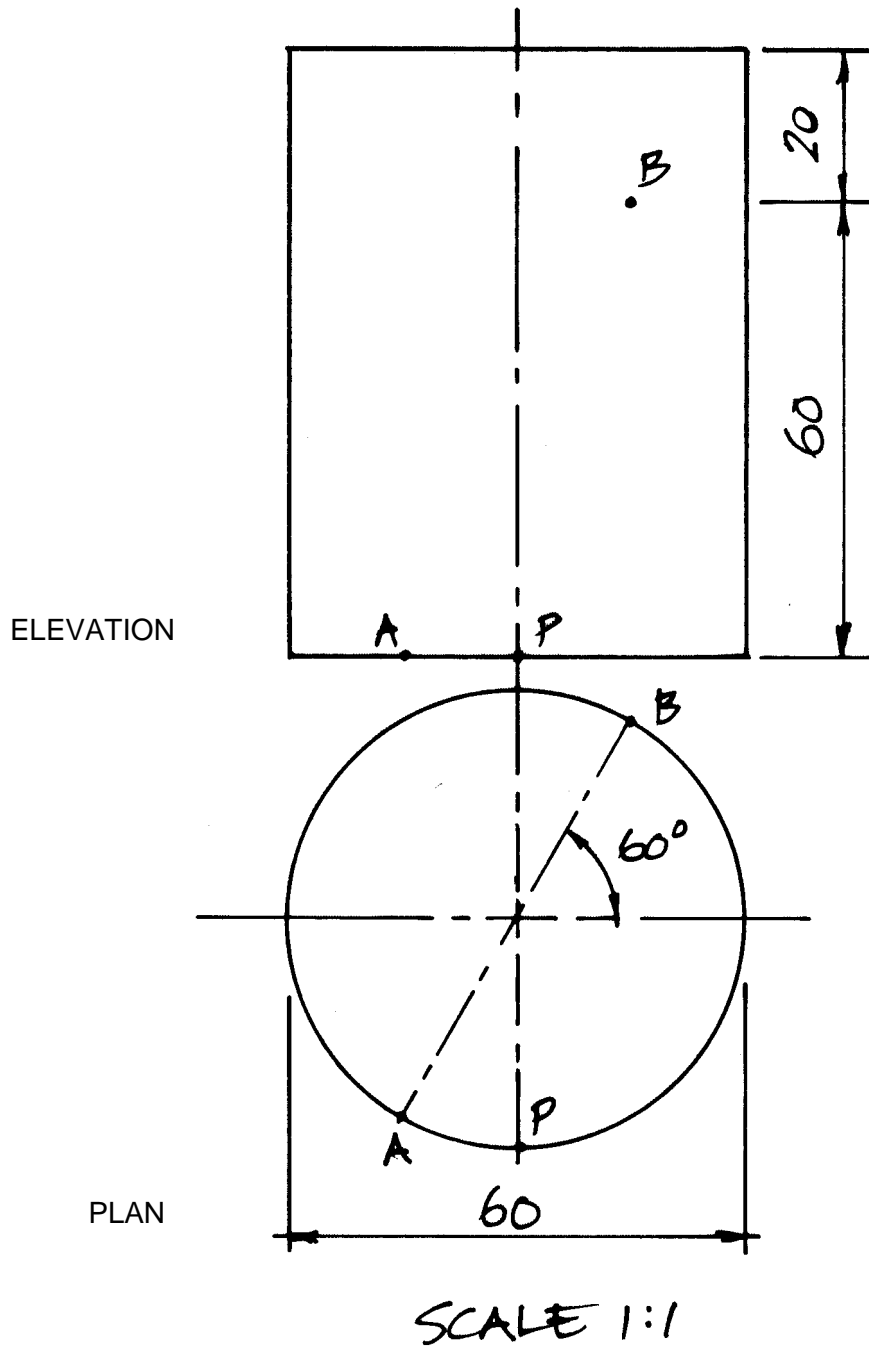

Figure 5

Section B continues.

Section B (continued)

Question 7

- (a) Choose a suitable scale and design and draw one view of a cam mechanism which will be used to slide under a refrigerator (fridge). The mechanism will slide under and lift the refrigerator to allow a removalist's trolley to roll underneath.

The minimum gap between the refrigerator and the floor is 60 mm and the maximum trolley height is 90 mm.

The mechanism must achieve the maximum height of the trolley with a 90° rotation of an attached lever.

- (b) Draw a displacement graph to illustrate the motion of the cam.

SECTION C

Answer **ONE** question from this section.

This section assesses **Criteria 2 and 3** weighted 4 : 1 respectively.

Question 8

Figure 6 shows the plan view and incomplete elevation of a cylindrical fluted tuner control knob.

Using a scale of 2:1 redraw both views and complete the elevation.

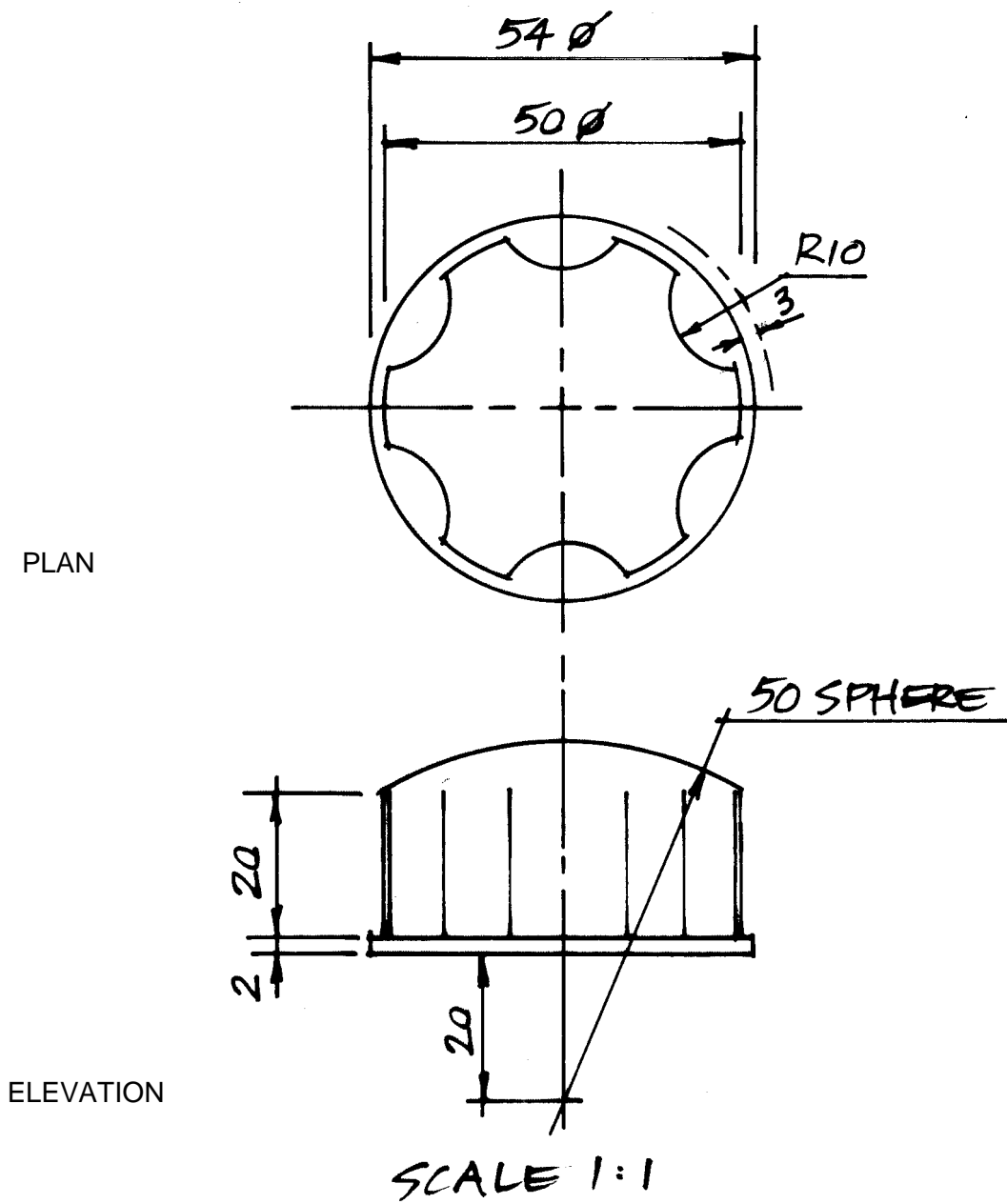

Figure 6

Section C continues.

Section C (continued)

Question 9

Figure 7 shows the plan and elevation of a rectangular based prism which has a square hole through it.

- (a) Redraw the given views.
- (b) Project an end elevation of the solid from the direction the arrow A.

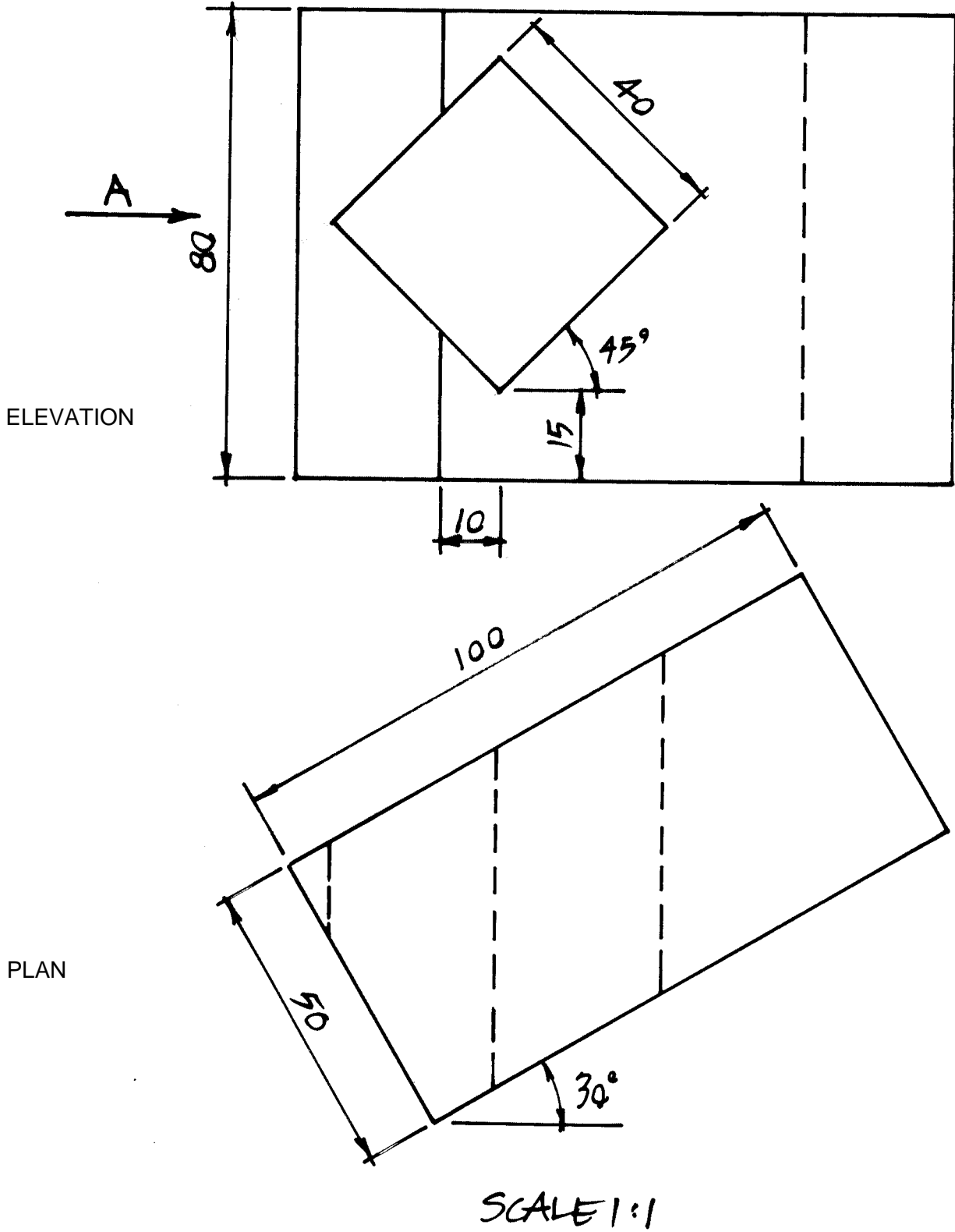

Figure 7

Section C continues.

Section C (continued)

Question 10

An isometric view of a shaped solid is shown in Figure 8.

- (a) Draw an elevation of the solid looking from the direction of the arrow B.
- (b) Project a plan from the elevation in First Angle Projection.
- (c) Project an auxiliary elevation from the plan which will show the true shape of the surface A.

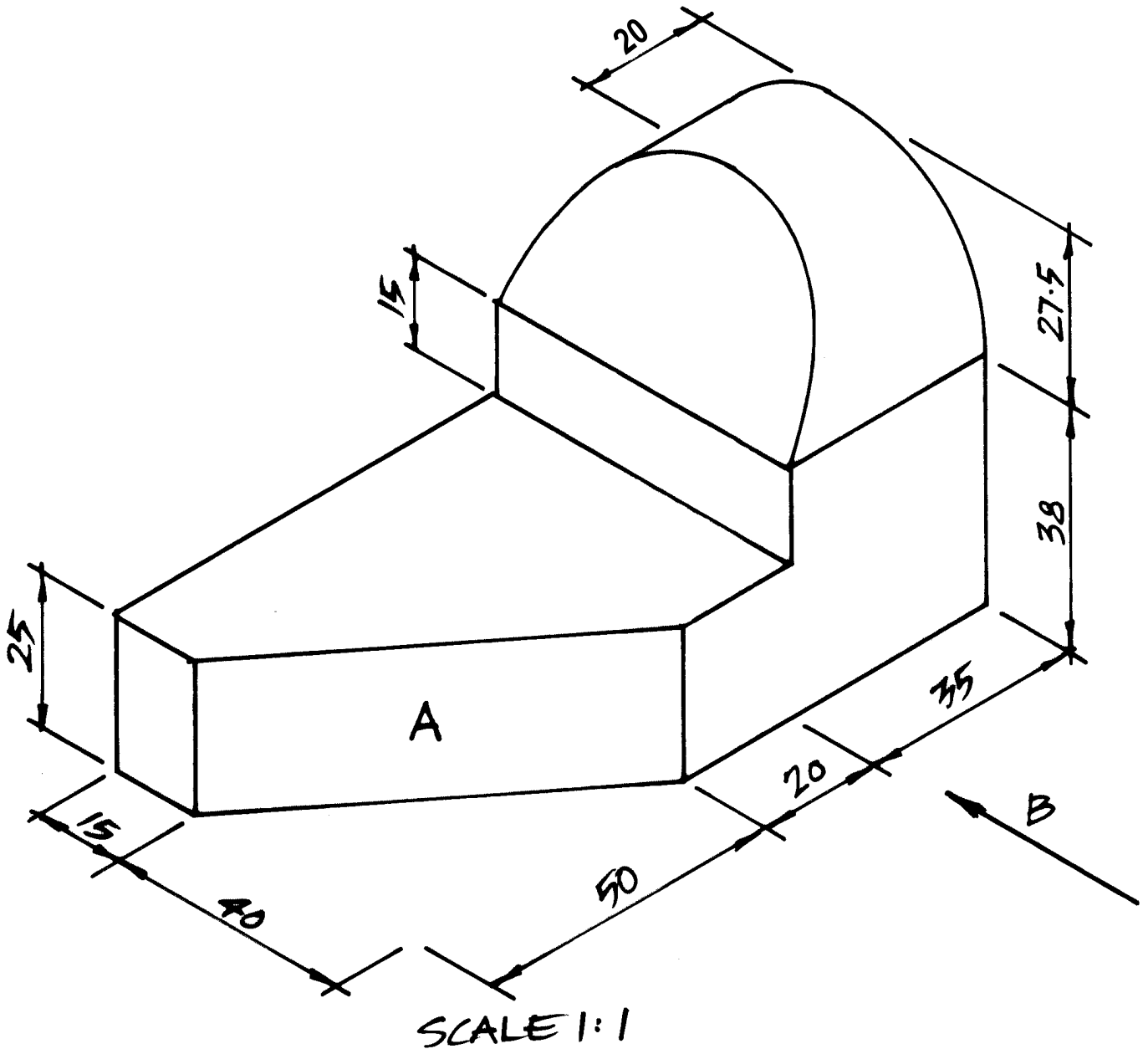

Figure 8



OFFICE OF TASMANIAN
ASSESSMENT, STANDARDS
& CERTIFICATION

This question paper and any materials associated with this examination (including answer booklets, cover sheets, rough note paper, or information sheets) remain the property of the Office of Tasmanian Assessment, Standards and Certification.