



OFFICE OF TASMANIAN  
ASSESSMENT, STANDARDS  
& CERTIFICATION

Tasmanian Certificate of Education  
External Assessment 2018

PLACE YOUR CANDIDATE  
LABEL HERE

# PHYSICAL SCIENCES

## (PSC315118)

### PART 1

Time: 36 minutes

Pages:	12
Questions:	5
Attachments:	Information Sheet

#### Candidate Instructions

1. You **MUST** make sure that your responses to the questions in this examination paper will show your achievement in the criteria being assessed.
2. Answer **ALL** questions. Answers must be written in the spaces provided on the examination paper.
3. You should make sure you answer all parts within each question so that the criterion can be assessed.
4. This examination is 3 hours in length. It is recommended that you spend approximately 36 minutes in total answering the questions in this booklet.
5. The 2018 External Examination Information Sheet for Physical Sciences can be used throughout the examination.
6. A TASC approved calculator can be used throughout the examination.
7. All written responses must be in English.

On the basis of your performance in this examination, the examiners will provide a result on the following criterion taken from the course statement:

**Criterion 4** Apply concepts and processes of atomic properties and nuclear reactions.

Criterion 4 Total:	/32
--------------------	-----

**BLANK PAGE**

## Additional Instructions for Candidates

Show all working in your answers to numerical questions. Some credit will be given for unsimplified answers. Credit cannot be given for an incorrect answer unless it is accompanied by details of the working. Appropriate units must be included.

**Note:**

When candidates are asked to 'show that':

- A candidate should calculate their own answer to the appropriate number of significant figures and use this subsequently.
- A candidate who is unable to determine the required value should use the value given by the examiner to answer the subsequent parts of the question.

**Question 1**

(a) Write the full isotopic symbol for magnesium-26. (1 mark)

.....

(b) Use the symbol given in part (a) to identify and define the following terms:  
• Atomic number  
• Mass number (2 marks)

.....  
.....  
.....  
.....  
.....

(c) The mass spectrum of a naturally occurring sample of magnesium is shown below. Determine the relative atomic mass of this sample. (2 marks)

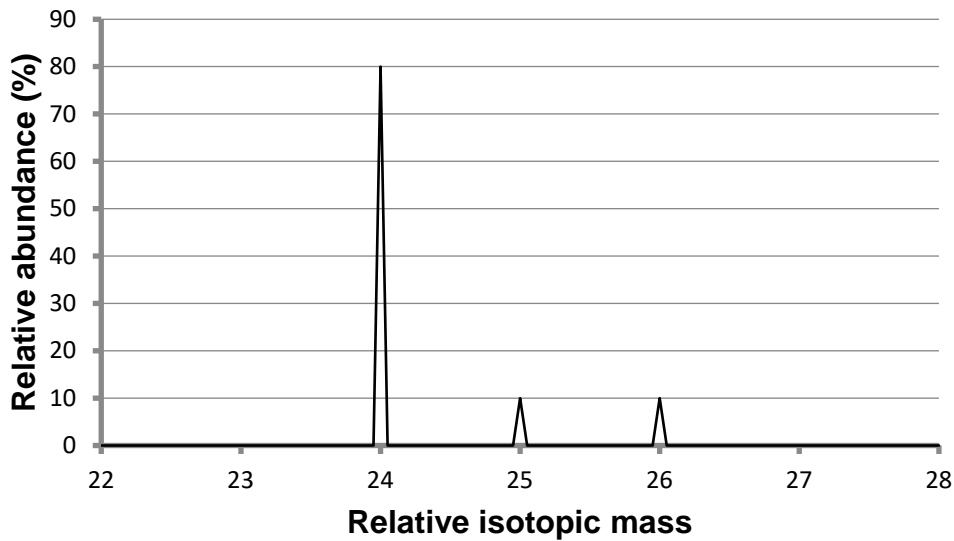

.....  
.....  
.....  
.....  
.....

**Question 1 continues.**

**Question 1 (continued)**

**For  
Marker  
Use  
Only**

(d) Explain why the atomic radius of magnesium-26 is smaller than that of sodium-23, even though it has more subatomic particles.

(2 marks)

.....

.....

.....

.....

.....

## Question 2

For  
Marker  
Use  
Only

Three particles, X, Y and Z, have the following structures:

Particle	Number of protons	Number of neutrons	Electron configuration
X	15	16	2, 8, 5
Y	16	16	2, 8, 6
Z	16	17	2, 8, 7

- (a) Are any of these particles isotopes? Explain. (2 marks)

.....  
.....  
.....  
.....

- (b) State the group number and the period number of particle X. (1 mark)

Group number .....

Period number .....

- (c) Predict the valency of the particle Y. (1 mark)

.....  
.....

- (d) Predict if any of the particles X, Y or Z are stable ions? Explain. (3 marks)

Prediction: .....

Explanation: .....

.....  
.....  
.....  
.....  
.....  
.....  
.....

**Question 3**

Emissions from uranium and radium were studied during early research into radioactivity.

- (a) A researcher identified that different types of rays were being produced. Some of the rays were able to penetrate thick substances. Identify the ray. (1 mark)

.....

Some of the rays did not 'rush off into space with the velocity of light, but could be bottled up'. These emissions rapidly lost their electrical effects. Identify the ray.

.....

- (b) The radiation count from radium is much higher than that of an equal mass of uranium. Explain this observation. (2 marks)

.....

.....

.....

.....

- (c) What is the difference between the radiation from uranium decaying and the radiation from a mobile phone? (1 mark)

.....

.....

Modern researchers have to follow strict safety guidelines when working with radioisotopes. Two of the rules are given below:

- Keep a distance between yourself and the radioisotope.
- Do not eat or drink while in a room where radioisotopes are handled.

- (d) By referring to the properties of nuclear decay radiation, explain why it is important to follow these guidelines. (4 marks)

.....

.....

.....

.....

.....

.....

.....

.....

**BLANK PAGE**



**Question 4**

When uranium-238 is bombarded by neutrons, uranium-239 is formed.

- (a) Write a nuclear equation to represent this reaction. (1 mark)

.....  
.....

Uranium-239 then undergoes nuclear decay to become neptunium-239. The nuclear reaction occurring is partly represented below:

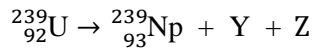

- (b) Identify the decay products: (1 mark)

Y: .....

Z:.....

Once in the environment, neptunium quickly reacts to form neptunium dioxide.

- (c) Would the half-life of neptunium dioxide be **greater than, the same as, or less than** the original neptunium? Explain your answer. (2 marks)

The half-life of neptunium dioxide is .....  
the original neptunium.

Explanation: .....

.....  
.....  
.....  
.....

**Question 5**

**For  
Marker  
Use  
Only**

The half-life of a radioisotope is 9 months.

- (a) Calculate the fraction of the radioisotope remaining after 3 years. (2 marks)

.....

.....

.....

.....

- (b) At the start of the school year, a student set up a Geiger counter and recorded the following measurements:

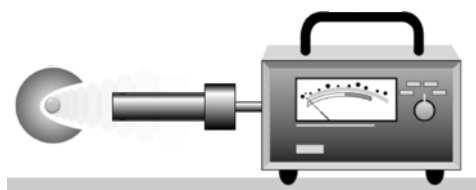

	Counts in 300 seconds
No radioisotope present	102
Radioisotope present at a set distance	3432

- (i) Why is it necessary to take the measurement with no radioisotope present? (1 mark)

.....

.....

**Question 5 continues.**

**Question 5 (continued)**

**For  
Marker  
Use  
Only**

The experiment was repeated 9 months later.

- (ii) Determine the expected reading on the Geiger counter with the radioisotope present. (2 marks)

.....

.....

.....

.....

.....

.....

- (iii) Even though the student's calculation was correct, the results from the second experiment varied slightly from that calculated. Explain. (1 mark)

.....

.....

.....



OFFICE OF TASMANIAN  
ASSESSMENT, STANDARDS  
& CERTIFICATION

*This question paper and any materials associated with this examination (including answer booklets, cover sheets, rough note paper, or information sheets) remain the property of the Office of Tasmanian Assessment, Standards and Certification.*



OFFICE OF TASMANIAN  
ASSESSMENT, STANDARDS  
& CERTIFICATION

Tasmanian Certificate of Education  
External Assessment 2018

PLACE YOUR CANDIDATE  
LABEL HERE

# PHYSICAL SCIENCES

## (PSC315118)

### PART 2

Time: 36 minutes

Pages:	12
Questions:	5
Attachments:	Information Sheet

#### Candidate Instructions

1. You **MUST** make sure that your responses to the questions in this examination paper will show your achievement in the criteria being assessed.
2. Answer **ALL** questions. Answers must be written in the spaces provided on the examination paper.
3. You should make sure you answer all parts within each question so that the criterion can be assessed.
4. This examination is 3 hours in length. It is recommended that you spend approximately 36 minutes in total answering the questions in this booklet.
5. The 2018 External Examination Information Sheet for Physical Sciences can be used throughout the examination.
6. A TASC approved calculator can be used throughout the examination.
7. All written responses must be in English.

On the basis of your performance in this examination, the examiners will provide a result on the following criterion taken from the course statement:

**Criterion 5** Apply concepts and processes of motion and force.

Criterion 5 Total:	/32
--------------------	-----

## Additional Instructions for Candidates

Show all working in your answers to numerical questions. Some credit will be given for unsimplified answers. Credit cannot be given for an incorrect answer unless it is accompanied by details of the working. Appropriate units must be included.

**Note:**

When candidates are asked to 'show that':

- A candidate should calculate their own answer to the appropriate number of significant figures and use this subsequently.
- A candidate who is unable to determine the required value should use the value given by the examiner to answer the subsequent parts of the question.

Spare diagrams have been provided at the end of the booklet. If you use a spare diagram, please annotate that you have done so on the question that you are answering.

**Question 6**

Two athletes, a rower and a runner, were discussing which of them had the greater average speed during their respective competitions.

- The runner completed a 5000 m race in 20 minutes. The finish line of the running track is 140 m due east of the start.
- The rower completed the 2000 m course at an average speed of  $16.0 \text{ km h}^{-1}$ .

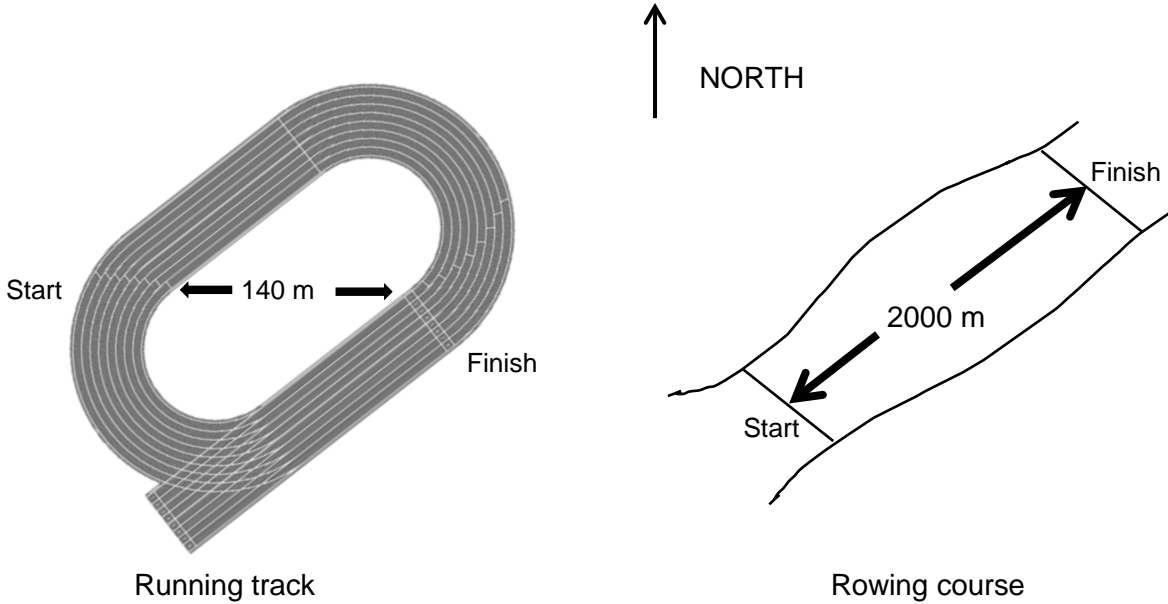

(a) Calculate which athlete has the greater average speed. (1 mark)

.....  
 .....  
 .....

(b) Calculate the average velocity of the runner in SI units. (2 marks)

.....  
 .....  
 .....  
 .....

**Question 7**

A stone is thrown horizontally from a ledge.

After 0.500 s, the stone's vertical velocity is  $4.91 \text{ m s}^{-1}$  down and its horizontal velocity is  $7.50 \text{ m s}^{-1}$  east.

Ignore air resistance when answering this question.

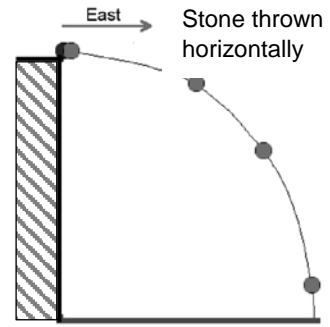

**For  
Marker  
Use  
Only**

(a) Sketch a vector diagram to represent the velocity of the stone at this time. (1 mark)

(b) Use your vector diagram to calculate the velocity of the stone at this time. (2 marks)

.....  
.....  
.....  
.....  
.....

(c) If the stone takes 1.13 s to reach the ground, from what height is it thrown? (1 mark)

.....  
.....  
.....  
.....

**Question 7 continues.**



**Question 7 (continued)**

Another stone is dropped from the ledge at the same height.

(d) Sketch graphs to show:

(3 marks)

- How the velocity of this stone varies with time.

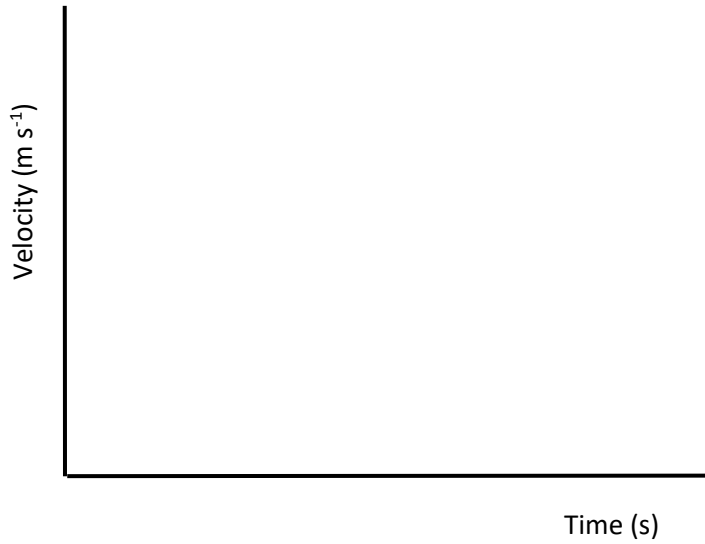

- How the distance travelled by the stone varies with time.

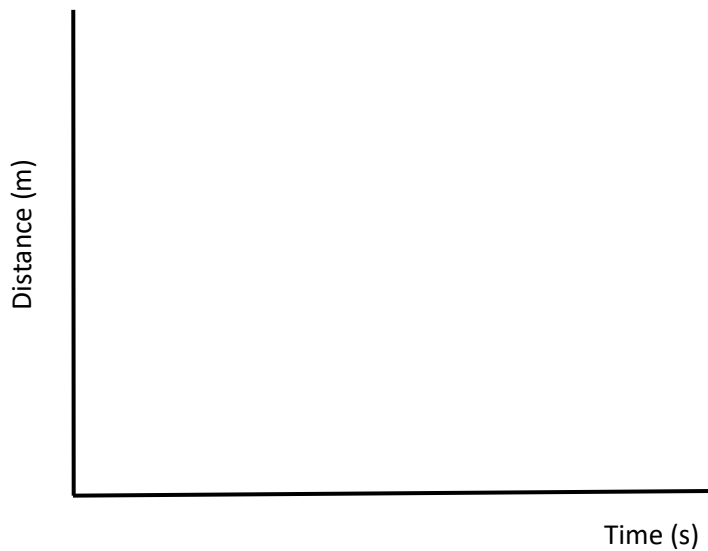

**Question 8**

A ball is projected vertically up, allowed to bounce, then caught. The graph showing how the velocity of the ball changes with time is given below:

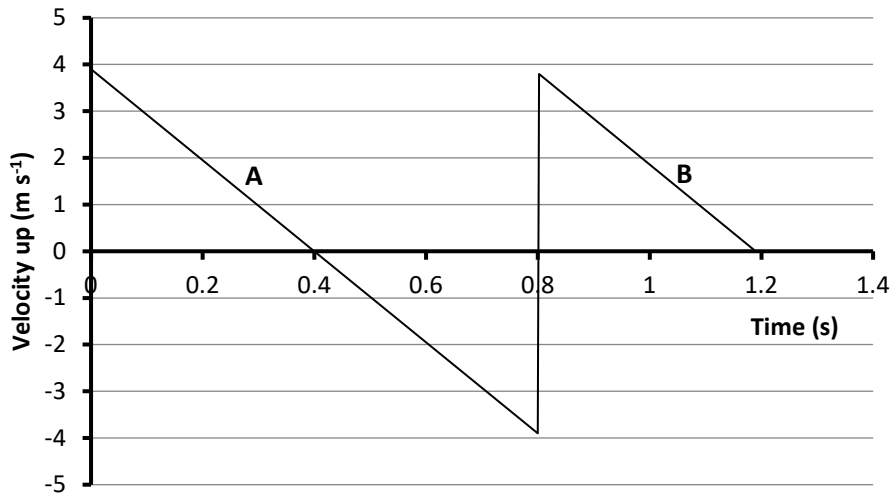

- (a) At what stage of the ball's flight is it at 0.4 s? (1 mark)

.....  
 .....

- (b) Why are the gradients of the lines labeled **A** and **B** the same? (1 mark)

.....  
 .....

- (c) Calculate the **approximate** displacement of the ball during the time period recorded. (2 marks)

.....  
 .....

**Question 8 continues.**

**Question 8 (continued)**

**For  
Marker  
Use  
Only**

(d) On the diagrams below, draw **labelled** vector(s) to represent the force(s) acting, if any, on the ball at the positions indicated:

- Position X is just after the ball is projected vertically up.
- Position Y is at the ball's maximum height.
- Position Z is the instant the ball is stationary during its bounce on the ground.

(3 marks)

**X**

**Y**

**Z**



**Question 9**

A space craft is carrying an astronaut back to Earth. The forces acting on the space craft as it travels down through the atmosphere are shown below.

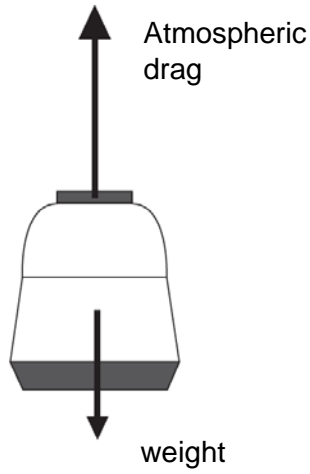

- (a) Are these forces an action/reaction pair?  
Explain your answer. (2 marks)

.....

.....

.....

.....

- (b) Describe the motion of the space craft when it experiences the forces shown on the diagram above. Refer to one of Newton's laws when answering this question. (2 marks)

.....

.....

.....

.....

.....

**Question 9 continues.**

**Question 9 (continued)**

**For  
Marker  
Use  
Only**

During all stages of the descent the astronaut is firmly secured to a specially shaped seat.

- (c) Explain why this is necessary. (2 marks)

.....  
.....  
.....  
.....  
.....

The space craft has a mass of 890 kg.

- (d) Calculate the weight of the space craft. (1 mark)

.....  
.....

When the space craft is travelling at  $5.50 \text{ m s}^{-1}$ , the engines operate for 3.50 s to reduce its speed. The resultant upward force on the space craft is 670 N. Ignore atmospheric drag.

- (e) Calculate the force generated by the engines. (2 marks)

.....  
.....  
.....  
.....

- (f) The maximum speed for safe landing is  $3 \text{ m s}^{-1}$ . Calculate if these engines are able to reduce the speed of the descent module sufficiently. (2 marks)

.....  
.....  
.....  
.....  
.....

**Question 10**

A footballer kicks a stationary soccer ball, of mass 440 g, giving it a velocity of  $32.0 \text{ m s}^{-1}$  east as it leaves his boot.

The acceleration of the ball is  $3.48 \times 10^3 \text{ m s}^{-2}$  east.



- (a) Calculate the distance travelled by the ball during the time the boot is in contact with the ball. (1 mark)

.....  
.....  
.....

- (b) Show that the magnitude of the force of the kick on the ball is approximately 1500 N. (1 mark)

.....  
.....  
.....

- (c) Determine the change in momentum of ball. (1 mark)

.....  
.....  
.....

- (d) Calculate the time of impact using the concept of impulse. (1 mark)

.....  
.....  
.....

SPARE DIAGRAMS

Question 7 (d)

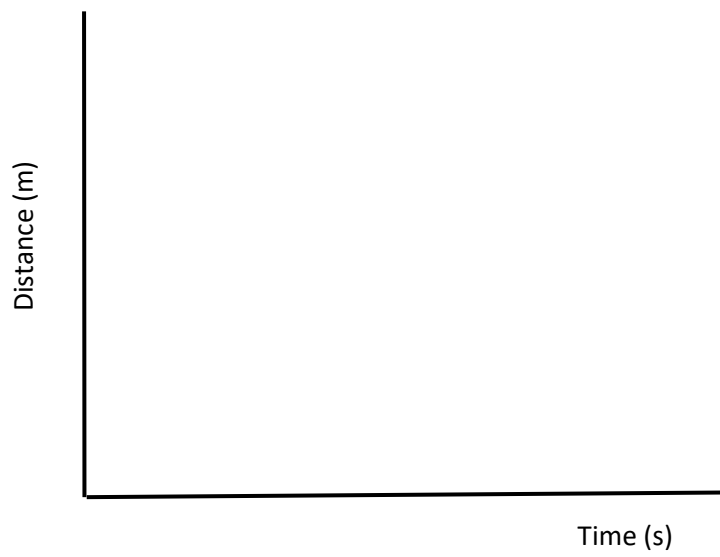
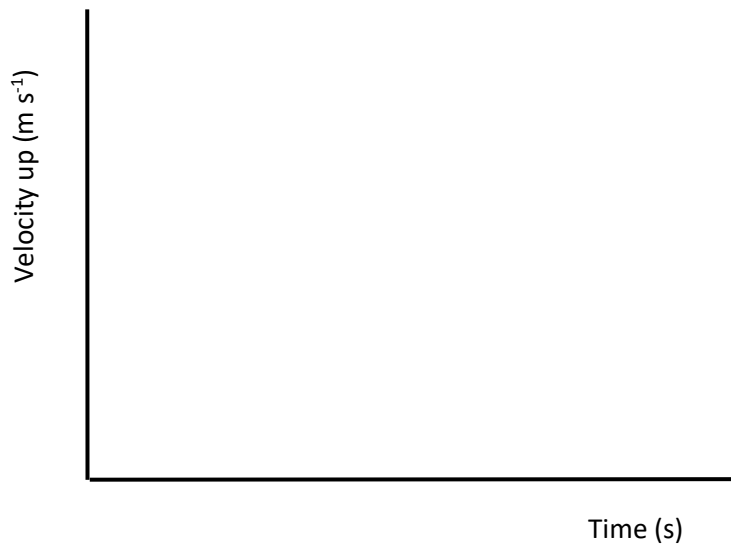

Question 8 (d)

X Y Z





OFFICE OF TASMANIAN  
ASSESSMENT, STANDARDS  
& CERTIFICATION

---

*This question paper and any materials associated with this examination (including answer booklets, cover sheets, rough note paper, or information sheets) remain the property of the Office of Tasmanian Assessment, Standards and Certification.*





OFFICE OF TASMANIAN  
ASSESSMENT, STANDARDS  
& CERTIFICATION

Tasmanian Certificate of Education  
External Assessment 2018

PLACE YOUR CANDIDATE  
LABEL HERE

# PHYSICAL SCIENCES

## (PSC315118)

### PART 3

Time: 36 minutes

Pages:	12
Questions:	5
Attachments:	Information Sheet

#### Candidate Instructions

1. You **MUST** make sure that your responses to the questions in this examination paper will show your achievement in the criteria being assessed.
2. Answer **ALL** questions. Answers must be written in the spaces provided on the examination paper.
3. You should make sure you answer all parts within each question so that the criterion can be assessed.
4. This examination is 3 hours in length. It is recommended that you spend approximately 36 minutes in total answering the questions in this booklet.
5. The 2018 External Examination Information Sheet for Physical Sciences can be used throughout the examination.
6. A TASC approved calculator can be used throughout the examination.
7. All written responses must be in English.

On the basis of your performance in this examination, the examiners will provide a result on the following criterion taken from the course statement:

**Criterion 6** Apply concepts and processes of conservation in physics.

Criterion 6 Total:	/32
--------------------	-----

**BLANK PAGE**

## Additional Instructions for Candidates

Show all working in your answers to numerical questions. Some credit will be given for unsimplified answers. Credit cannot be given for an incorrect answer unless it is accompanied by details of the working. Appropriate units must be included.

**Note:**

When candidates are asked to 'show that':

- A candidate should calculate their own answer to the appropriate number of significant figures and use this subsequently.
- A candidate who is unable to determine the required value should use the value given by the examiner to answer the subsequent parts of the question.

**Question 11**

An electric bicycle (eBike) is a bicycle that has a small electric motor attached that can be activated to assist the rider.

A rider starts from rest at A and travels up a hill, with the aid of the motor, for 50.0 m, reaching a speed of  $6.70 \text{ m s}^{-1}$  at B. This takes 12.5 s and her height above the original starting point increases by 3.00 m.

The combined mass of the rider and the eBike is 80 kg.

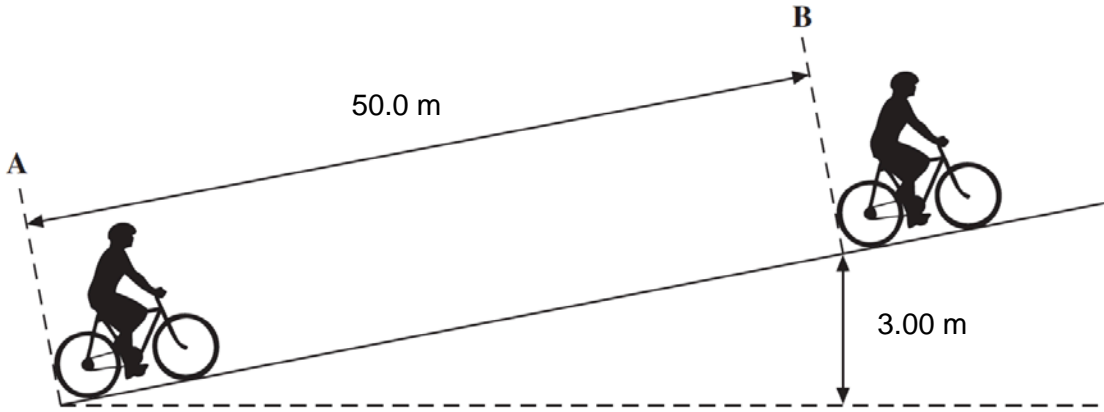

- (a) Outline the energy changes occurring as the rider and eBike move from A to B. (3 marks)

.....

.....

.....

.....

.....

.....

.....

.....

.....

.....

- (b) Calculate the kinetic energy of the rider and the eBike at B. (1 mark)

.....

.....

.....

**Question 11 continues.**

**Question 11 (continued)**

- (c) Hence, show that the increase in total mechanical energy of the rider and the eBike at B is about 4000 J. (2 marks)

.....  
.....  
.....  
.....

Between A and B, the work done by the electric motor is 3700 J and the work done by the rider peddling is 5300 J.

- (d) Calculate the average power output of the electric motor in moving from A to B. (1 mark)

.....  
.....

- (e) Calculate the average frictional force experienced by the eBike and rider. (3 marks)

.....  
.....  
.....  
.....  
.....  
.....

The battery on the eBike has a capacity of 0.418 kWh.

- (f) Calculate what percentage of the battery's capacity is used in moving the rider from A to B. (2 marks)

.....  
.....

**Question 12**

A toy railway carriage **X**, of mass 61.0 g, is travelling along a level rail at a velocity of  $0.320 \text{ m s}^{-1}$  east when it collides with carriage **Y**, of mass 92.0 g, travelling west at  $0.620 \text{ m s}^{-1}$ . As a result of the collision, the two carriages become locked together and continue to move along the rail.



- (a) Calculate the initial momentum of the system. (2 marks)

.....

.....

.....

.....

.....

- (b) Calculate the velocity of carriage **Y** after the collision. (2 marks)

.....

.....

.....

.....

.....

- (c) The collision between the two carriages is **inelastic**. Explain the meaning of this term. (1 mark)

.....

.....

**Question 13**

**For  
Marker  
Use  
Only**

An electrical component is rated at 2.5 W, 3 V for normal operation.

- (a) Calculate the resistance of the component at this voltage. (1 mark)

.....  
.....  
.....

When the component is connected to a 1.5 V battery, the current flowing is 530 mA.

- (b) Calculate the resistance of the component at this voltage. (1 mark)

.....  
.....  
.....

- (c) Classify the component as either ohmic or non-ohmic, giving a reason for your answer. (2 marks)

Classification: .....

Reason: .....

.....  
.....  
.....

- (d) Identify a common electrical component that has this characteristic. (1 mark)

.....  
.....

**Question 14**

A girl rubs her feet on a wool rug on a dry day and becomes charged.

- (a) If the charge on the girl is  $-42 \mu\text{C}$ , determine the number of excess electrons on her. (2 marks)

.....

.....

.....

.....

- (b) The charged girl then touches her brother's ear. Both receive a mild electric shock. Explain. (2 marks)

.....

.....

.....

.....

/ 4

**Question 15**

Two circuits are constructed from identical components. The pair of light globes,  $R_1$  and  $R_2$ , are connected differently to the battery, as shown in the circuit diagrams below.

The resistance of the globe  $R_1$  is lower than the resistance of the globe  $R_2$ .

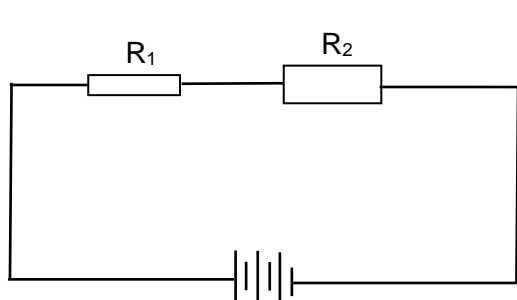

**CIRCUIT 1**

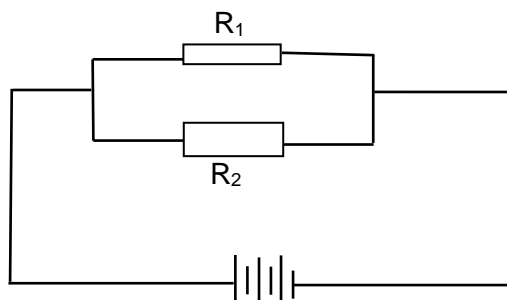

**CIRCUIT 2**

**Question 15 continues.**



**Question 15 (continued)**

**For  
Marker  
Use  
Only**

(a) In CIRCUIT 2 place a voltmeter to measure the potential difference across  $R_1$  and an ammeter to measure the current flow through  $R_2$ . (1 mark)

(b) In CIRCUIT 1 will the light globe  $R_1$  in be **brighter than, the same brightness as, or dimmer than**, light globe  $R_2$ ?  
Explain your choice. (2 marks)

$R_1$  will be .....  $R_2$ .

Explanation: .....  
.....  
.....

(c) Will the brightness of light globe  $R_1$  in CIRCUIT 1 be **brighter than, the same brightness as, or dimmer than** light globe  $R_1$  in CIRCUIT 2?  
Explain your choice. (2 marks)

$R_1$  in CIRCUIT 1 will be ..... than  $R_1$  in CIRCUIT 2.

Explanation: .....  
.....  
.....

(d) In which circuit, if any, will the battery last the greater time? (1 mark)

.....  
.....

**/ 6**

SPARE DIAGRAM

Question 15 (a)

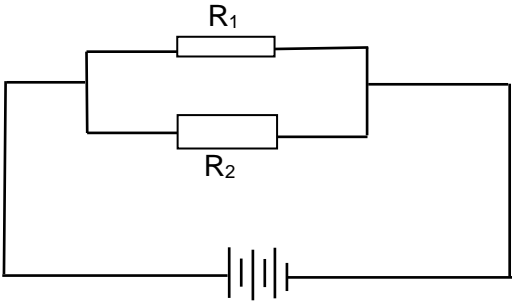

**CIRCUIT 2**

**BLANK PAGE**



OFFICE OF TASMANIAN  
ASSESSMENT, STANDARDS  
& CERTIFICATION

---

*This question paper and any materials associated with this examination (including answer booklets, cover sheets, rough note paper, or information sheets) remain the property of the Office of Tasmanian Assessment, Standards and Certification.*



OFFICE OF TASMANIAN  
ASSESSMENT, STANDARDS  
& CERTIFICATION

Tasmanian Certificate of Education  
External Assessment 2018

PLACE YOUR CANDIDATE  
LABEL HERE

# PHYSICAL SCIENCES

## (PSC315118)

### PART 4

Time: 36 minutes

Pages:	12
Questions:	6
Attachments:	Information Sheet

#### Candidate Instructions

1. You **MUST** make sure that your responses to the questions in this examination paper will show your achievement in the criteria being assessed.
2. Answer **ALL** questions. Answers must be written in the spaces provided on the examination paper.
3. You should make sure you answer all parts within each question so that the criterion can be assessed.
4. This examination is 3 hours in length. It is recommended that you spend approximately 36 minutes in total answering the questions in this booklet.
5. The 2018 External Examination Information Sheet for Physical Sciences can be used throughout the examination.
6. A TASC approved calculator can be used throughout the examination.
7. All written responses must be in English.

On the basis of your performance in this examination, the examiners will provide a result on the following criterion taken from the course statement:

**Criterion 7** Apply concepts and processes of chemical structures and properties.

Criterion 7 Total:	/32
--------------------	-----

**BLANK PAGE**

## Additional Instructions for Candidates

Show all working in your answers to numerical questions. Some credit will be given for unsimplified answers. Credit cannot be given for an incorrect answer unless it is accompanied by details of the working. Appropriate units must be included.

**Note:**

When candidates are asked to 'show that':

- A candidate should calculate their own answer to the appropriate number of significant figures and use this subsequently.
- A candidate who is unable to determine the required value should use the value given by the examiner to answer the subsequent parts of the question.

**Question 16****For  
Marker  
Use  
Only**

- (a) Complete the following table. Do not fill in the shaded parts of the table. (4 marks)

Chemical formula	Systematic name	Type of structure	
$\text{PF}_3$			
$\text{PbCrO}_4$			
$\begin{array}{c} \text{H} \\   \\ \text{H}-\text{C}-\text{C}\equiv\text{C}-\text{H} \\   \\ \text{Cl} \end{array}$			
$\begin{array}{c} \text{Br} \\   \\ \text{CH}_3\text{CHCHCH}_2\text{CH}_3 \\   \\ \text{CH}_3 \end{array}$			

- (b) Draw an electron dot diagram representing  $\text{PF}_3$ . (1 mark)

**/ 5**



**Question 17**

- (a) Predict if a precipitate will form when each pair of dilute solutions are mixed in separate test tubes.

The first row has been completed.

(1 mark)

Test tube	Solutions used	Does a precipitate form?
A	$\text{NaOH}_{(aq)}$ mixed with $\text{MgCl}_{2(aq)}$	yes
B	$\text{NaBr}_{(aq)}$ mixed with $\text{AgNO}_{3(aq)}$	
C	$\text{Na}_2\text{SO}_{4(aq)}$ mixed with $\text{Mg}(\text{NO}_3)_{2(aq)}$	

- (b) Write a net ionic equation to represent the chemical reaction occurring in test tube A.

(2 marks)

.....

.....

.....

.....

- (c) When the two solutions are mixed in test tube A, which ion(s), if any, would remain constant in number in the solution?

(1 mark)

.....

.....

**Question 18**

Sodium and sulfur are both in period 3 of the periodic table.

(a) Under normal conditions the chemical formula of solid sulfur is S<sub>8</sub>.

(i) What is the significance of the number '8' in the formula? (1 mark)

.....

.....

(ii) Consider a sample of solid sulfur, S<sub>8</sub>. Complete the following table to indicate the type(s) of bonds/forces present, their relative strength and the particles attracted by the force/bond. (2 marks)

Name of bond/force	Strength of bond/force	Particle(s) attracted

(b) The melting points of sodium (98°C) and sulfur (115°C) are not sufficient to show if these two elements have different structures.

State another property that could be used to show that they have different structures, explaining how the property suggested relates to the structure. (3 marks)

Property:

.....

.....

Explanation:

.....

.....

.....

.....

**Question 18 continues**

**Question 18 (continued)**

- (c) Sulfur and sodium react to form a compound. Predict if the melting point of the compound formed would vary significantly from the melting points of sodium and sulfur. Explain your answer. (2 marks)

Prediction: .....

Explanation: .....

.....

.....

.....

For  
Marker  
Use  
Only

/ 8

**Question 19**

- (a) Explain how the presence of polar bonds influences the melting point of water. Use a diagram to support your explanation. (3 marks)

.....

.....

.....

.....

.....

- (b) Explain how the structure of graphite makes it much softer than diamond. (2 marks)

.....

.....

.....

.....

/ 5

**BLANK PAGE**

**Question 20**

This question is based on the periodic table shown below. Letter codes (from **a** to **i**) are used instead of chemical symbols in the table.

For  
Marker  
Use  
Only

**Only use the letter codes given when answering the following questions.**

1	2							13	14	15	16	17	18
<b>a</b>									<b>b</b>	<b>c</b>	<b>d</b>	<b>e</b>	<b>f</b>
<b>g</b>	<b>h</b>											<b>i</b>	

(a) Using the letter code: (1 mark)

- give the formula for the most stable ion formed from element **c**.

.....

- give the formula for the element with the highest melting point in period 2.

.....

(b) Explain, in terms of bonding, how element **g** forms a compound with element **e**. (2 marks)

.....

.....

.....

.....

.....

(c) Give the letter code for the most reactive non-metal. (1 mark)

.....

.....

**Question 21**

Three hydrocarbons, labelled **A**, **B** and **C** are isomers.

They have the following properties:

- When one mole of each hydrocarbon is burnt in excess air, all three compounds produce four moles of carbon dioxide.
- A bromine solution is added to each of the compounds. Only **A** and **B** react immediately. **C** will only react when the mixture is exposed to UV light.
- Hydrogen chloride gas,  $\text{HCl}_{(g)}$ , is added to each of the compounds. When **A** reacts two isomers are formed, but the reaction of **B** results in the formation of one compound only.

(a) Define the term isomer. (1 mark)

.....  
.....

(b) Draw a structural formula for each of the compounds, based on their chemical properties. (3 marks)

**A**

**B**

**C**

**Question 21 continues**

**Question 21 (continued)**

- (c) Explain the role of bromine when identifying the isomers. Use a structural chemical equation to support your answer. (2 marks)

**For  
Marker  
Use  
Only**

.....

.....

.....

.....

**/ 6**



---

OFFICE OF TASMANIAN  
ASSESSMENT, STANDARDS  
& CERTIFICATION

---

*This question paper and any materials associated with this examination (including answer booklets, cover sheets, rough note paper, or information sheets) remain the property of the Office of Tasmanian Assessment, Standards and Certification.*





OFFICE OF TASMANIAN  
ASSESSMENT, STANDARDS  
& CERTIFICATION

Tasmanian Certificate of Education  
External Assessment 2018

PLACE YOUR CANDIDATE  
LABEL HERE

# PHYSICAL SCIENCES

## (PSC315118)

### PART 5

Time: 36 minutes

Pages:	12
Questions:	6
Attachments:	Information Sheet

#### Candidate Instructions

1. You **MUST** make sure that your responses to the questions in this examination paper will show your achievement in the criteria being assessed.
2. Answer **ALL** questions. Answers must be written in the spaces provided on the examination paper.
3. You should make sure you answer all parts within each question so that the criterion can be assessed.
4. This examination is 3 hours in length. It is recommended that you spend approximately 36 minutes in total answering the questions in this booklet.
5. The 2018 External Examination Information Sheet for Physical Sciences can be used throughout the examination.
6. A TASC approved calculator can be used throughout the examination.
7. All written responses must be in English.

On the basis of your performance in this examination, the examiners will provide a result on the following criterion taken from the course statement:

**Criterion 8** Apply concepts and processes of chemical reactions and reacting quantities.

Criterion 8 Total:	/32
--------------------	-----

## Additional Instructions for Candidates

Show all working in your answers to numerical questions. Some credit will be given for unsimplified answers. Credit cannot be given for an incorrect answer unless it is accompanied by details of the working. Appropriate units must be included.

**Note:**

When candidates are asked to 'show that':

- A candidate should calculate their own answer to the appropriate number of significant figures and use this subsequently.
- A candidate who is unable to determine the required value should use the value given by the examiner to answer the subsequent parts of the question.

**Question 22**

(a) Potassium metal is added to water.

(i) Balance the following chemical equation which represents the reaction occurring:

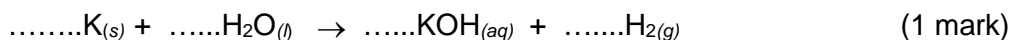
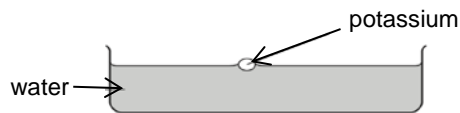

(ii) Give two (2) observations that would be made as the reaction proceeds. (1 mark)

.....  
.....

(b) When solid ammonium carbonate is added to hydrochloric acid solution, ammonium chloride solution, carbon dioxide gas and water are formed.

(i) Write a balanced chemical equation to represent this reaction. (2 marks)

.....  
.....

(ii) The pH of the solution is monitored as the reaction proceeds. The readings change. Explain this observation. (1 mark)

.....  
.....

(c) Write a balanced chemical equation to represent the following reaction:  
Nickel(II) hydroxide powder is added to a dilute solution of sulfuric acid. (2 marks)

.....  
.....

**Question 23**

**For  
Marker  
Use  
Only**

- (a) An oxide of nitrogen contains 36.8% by mass of nitrogen. Determine the empirical formula of the oxide. (2 marks)

.....

.....

.....

.....

.....

.....

- (b) If 1.00 mol of the oxide has a mass of 152.0 g, determine the molecular formula of the oxide. (1 mark)

.....

.....

**/ 3**

**Question 24**

**For  
Marker  
Use  
Only**

- (a) Calculate the percentage by mass of copper(II) ions,  $\text{Cu}^{2+}$ , in anhydrous copper(II) nitrate,  $\text{Cu}(\text{NO}_3)_2$ . ( $M_r(\text{Cu}(\text{NO}_3)_2) = 187.56$ ) (1 mark)

.....

.....

.....

Another form of this compound, hydrated copper(II) nitrate, has the chemical formula  $\text{Cu}(\text{NO}_3)_2 \cdot 3\text{H}_2\text{O}$ .

There is 0.140 mol of this compound present.

- (b) Determine the amount, in mol, present of: (1 mark)
- Nitrate ions,  $\text{NO}_3^-$ .

.....

- Water molecules,  $\text{H}_2\text{O}$

.....

- (c) Calculate the mass of the hydrated copper(II) nitrate present. (2 marks)

.....

.....

.....

.....

**/ 4**

**Question 25**

21.0 g of propane, C<sub>3</sub>H<sub>8</sub>, is burnt in excess air. The chemical equation representing the reaction occurring is given below:

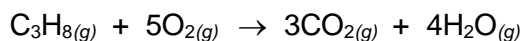

**For  
Marker  
Use  
Only**

- (a) Show that there is about 0.5 mol of propane burnt. (2 marks)

.....

.....

.....

.....

- (b) Determine the mass of oxygen required. (2 marks)

.....

.....

.....

.....

.....

- (c) Determine the mass of products formed. (1 mark)

.....

.....

.....

**/ 5**

**Question 26**

**For  
Marker  
Use  
Only**

When reporting that several tonnes of sodium hydroxide, commonly called caustic soda, had been spilt into the ocean it was stated that '**caustic soda neutralises when mixed with sea water**'.

Seawater has a pH of about 8.1.

- (a) Based on chemical principles, comment on the accuracy of this statement. (2 marks)

.....  
.....  
.....  
.....  
.....

The concentration of sodium ions,  $\text{Na}^+_{(aq)}$ , in seawater is  $0.469 \text{ mol L}^{-1}$ .

- (b) If 20.0 g of sodium hydroxide, NaOH, is dissolved in 2.00 L of seawater, calculate the new concentration, in  $\text{mol L}^{-1}$ , of sodium ions in this solution. (3 marks)

.....  
.....  
.....  
.....  
.....  
.....

**/ 5**

**Question 27**

Some industrial cleaners have a concentration of about 15 mol L<sup>-1</sup> ammonia in aqueous solution.

- (a) Use three of the following six words to best describe this ammonia solution, giving reasons for your answer. (3 marks)

strong      concentrated      weak      dilute      acid      base

Description: .....

.....

Reasons: .....

.....

.....

.....

The concentration of household ammonia is in the range of 5% to 10% by mass.

A sample of household ammonia cleaner was analysed by titrating it against hydrochloric acid solution, using an appropriate indicator.

The reaction occurring is represented by the following chemical equation:

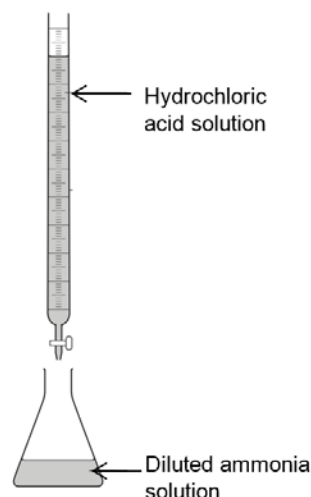
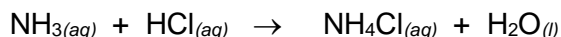

The following steps were carried out:

- 25.0 mL of the ammonia cleaner was diluted to 250 mL using distilled water.
- 21.9 mL of the hydrochloric acid solution, of concentration 0.425 mol L<sup>-1</sup>, was needed to neutralise 20.0 mL of the diluted ammonia solution.

- (b) Show that the concentration of the diluted ammonia solution used in the titration is about 0.5 mol L<sup>-1</sup>. (2 marks)

.....

.....

.....

.....

.....

**Question 27 continues.**



**Question 27 (continued)**

- (c) Calculate the percentage, by mass, of ammonia in the undiluted household cleaner. Assume 1.00 mL of the undiluted household ammonia solution weighs 1.00 g. (3 marks)

.....

.....

.....

.....

.....

.....

**For  
Marker  
Use  
Only**

**/ 8**

**BLANK PAGE**

**BLANK PAGE**



OFFICE OF TASMANIAN  
ASSESSMENT, STANDARDS  
& CERTIFICATION

---

*This question paper and any materials associated with this examination (including answer booklets, cover sheets, rough note paper, or information sheets) remain the property of the Office of Tasmanian Assessment, Standards and Certification.*